



Schenectady County
Purchasing Department
ADDENDUM

620 State St.-2nd Floor
Schenectady, NY 12305
Purchasing@schenectadycounty.com
518.388.4240

RFB-2022-59
JAIL KITCHEN CONVEYOR

ADDENDUM #3

Issued Date 6/9/22

The purpose of this addendum is to provide detailed information to all Bidders. This addendum is hereby included in and made part of the Contract Documents, whether or not attached thereto. Receipt of this Addendum must be acknowledged on the bid form.

CONTENTS/RESPONSE TO QUESTIONS/REFERENCE TO ATTACHMENTS

Please acknowledge this addendum on your bid form.

PLEASE SEE THE ATTACHED DRAWING OF THE UNIT THAT IS TO BE BID.

PLEASE DISREGARD PAGE 23 IN THE ORIGINAL BID PACKET, PLEASE USE THE ATTACHED DRAWING PROVIDED IN ADDENDA FORBIDDING ONLY.

PLEASE NOTE, THAT THE BID DATE HAS CHANGED TO JUNE 23, 2022 AT 2PM.

COOK'S MODEL NUMBER: GC100

ONE (1) FIVE HOT SLIM LINE TRAY ASSEMBLE CONVEYOR WITH CONTROLS AND ROLLERS

ONE (1) FOUR COLD FOOD SLIM LINE TRAY ASSEMBLE CONVEYOR WITH ROLLER.

TWO UNITS TO BE BOLTED TOGETHER WITH STAND FIELD JOINT TO BE FLUSH ONE UNIT.

VOLTAGE: 208V/3PH/60HZ

PLEASE NOTE THAT THE LANGUAGE ON PAGE 21 ABOUT A NEW STEAMER SHOULD BE IGNORED.

QUESTIONS AND ANSWERS:

1. Will the bid date be moved to a later date ? **Bid date has been moved to June 23, 2022, at 2:00 PM**
2. Is the bidder required to install/ purchase the convection steamer ? **Please disregard the steamer. This is for the conveyor only. Please see attached drawing with this addenda.**
 - a. REF- page 21, "**1. SCOPE** 1.1. Schenectady County is seeking to replace an existing Slim Line Tray Assembly Conveyor with a new one. The following are the



Schenectady County
Purchasing Department
ADDENDUM

620 State St.-2nd Floor
Schenectady, NY 12305
Purchasing@schenectadycounty.com
518.388.4240

specifications for the purchase, delivery, and installation of a **new steamer** and conveyor and the scope of work for the installation, testing, and training. “

- b. We're not gas techs unfortunately and we want make sure the SOW is just the conveyor.
3. Does the unit need NSF testing done? – **County will look into.**
 - a. All components are stainless steel and NSF listed such as the grey tube(the grey/blue means good for food contact where as white/black are used for drain applications) and Interroll bearings as well which we use everyday in our dish room designs.
4. Should we follow the drawing that was provided to us at the site meeting as the unit you need and **not the unit below**? **Please quote based on drawing provided in this addenda, not the drawing below.**

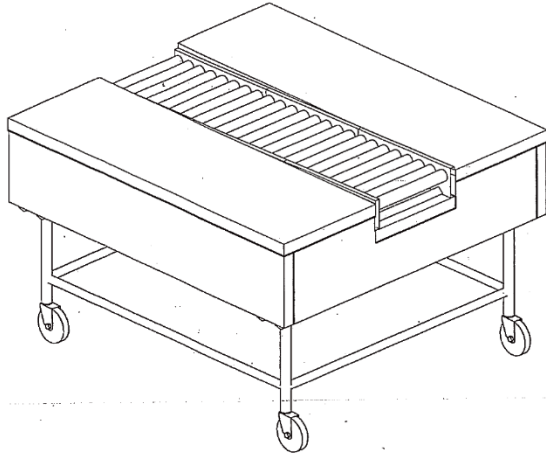

5. In addition to question #4, the length should be followed 180” as per drawing **that is provided on site meeting** ? **Please see attached drawing in this addenda only.**
6. With the drawing below, is the bidder required to install the hot and cold wells? **Please see attached drawing and note below.**
ONE (1) FIVE HOT SLIM LINE TRAY ASSEMBLE CONVEYOR WITH CONTROLS AND ROLLERS
ONE (1) FOUR COLD FOOD SLIM LINE TRAY ASSEMBLE CONVEYOR WITH ROLLER.
7. IF so, is the quantity correct on site visit drawing? **See answer in question 6 and drawing attached in this addenda only.**



Schenectady County
 Purchasing Department
ADDENDUM

620 State St.-2nd Floor
 Schenectady, NY 12305
Purchasing@schenectadycounty.com
 518.388.4240

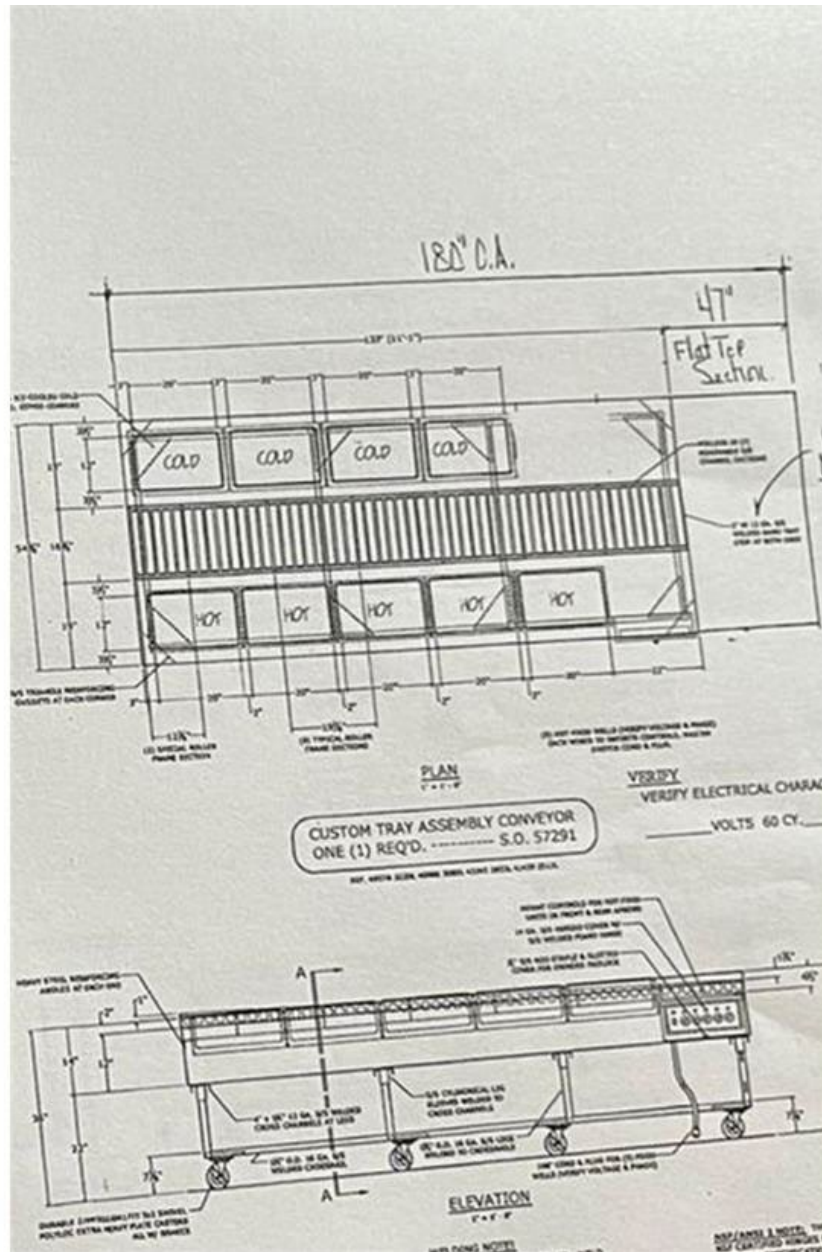

8. IF questions 8 is not correct, is bidder designing the unit FOR the kitchen team to place the HOT/COLD wells with a wire chase(a box and plugs) below ? – see blow of sample pic **Please go off of the attached drawings, not the drawing presented below.**



Schenectady County
Purchasing Department
ADDENDUM

620 State St.-2nd Floor
Schenectady, NY 12305
Purchasing@schenectadycounty.com
518.388.4240

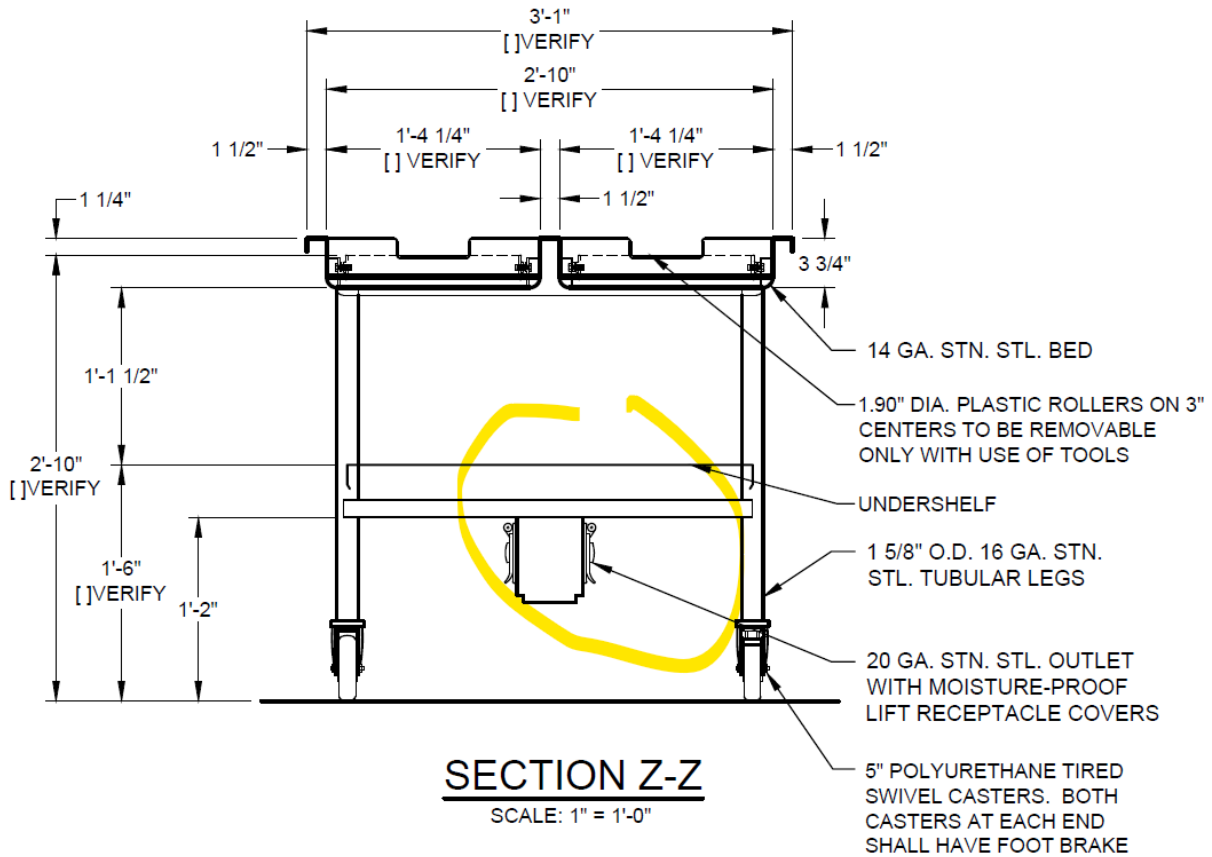

END OF ADDENDUM #3